



**City of Aliso Viejo
Building Division**
12 Journey, Suite 100
Aliso Viejo, CA 92656
(949)425-2540 Fax (949)425-3899
www.cityofaliso Viejo.com

Residential Photovoltaic Incentives & Plan Submittal Guidelines

REVIEW:

Photovoltaic systems will receive over-the-counter review when the items indicated in the Submittal Guidelines below are complete. If plans are submitted for review, the plan review will be expedited at no additional cost to the applicant (1 to 5 business days).

Note: Home Owner's Association is waived for permit issuance (Owner must still comply with their CC&R's).

FEES:

Permit fees will receive a 25% fee reduction. Contact the Building Department for further information.

PLAN SUBMITTAL GUIDELINES

ADMINISTRATIVE

Complete permit application form. The permit application can be downloaded at www.cityofaliso Viejo.com. The forms must be submitted to the Building Department in person. The Building Department counter hours are 7:30am to 12pm, Monday through Friday, closed alternate Fridays.

1. The following clearances or approvals are required before a building permit can be issued:
 - a. Building and Safety

SITE PLAN

2. Provide full dimensioned site plan. Show lot size, street, alley, easements, parking spaces, location, size and use of all structures on the lot, and property line. Identify property lines, lot dimensions, and distance to property line.
3. Show size, location, type of main service panel (ie. top-feed, center-fed), location of all solar arrays and equipment.

LINE DIAGRAMS

4. Provide a minimum of a single line diagram showing:
 - a. Array configuration
 - b. Array wiring identified
 - c. Combiner/junction box identified
 - d. Conduit/wiring from array to inverter identified
 - e. DC grounding system specified
 - f. Disconnecting means specified
 - g. Inverter specified
 - h. Conduit/wiring from inverter to Utility point of connection identified
 - i. AC grounding and system grounding specified
 - j. Point of connection attachment method identified

INVERTER INFORMATION

5. Provide inverter manufacturer specification sheet

PV MODULE INFORMATION

6. Provide module manufacturer specification sheet

ARRAY INFORMATION

7. Show the following on the plan:
- | | |
|---------------------------------------|---------------------------|
| a. Number of module in series | e. Operating current |
| b. Number of parallel source circuits | f. Maximum system voltage |
| c. Total number of modules | g. Short-circuit current |
| d. Operating voltage | |

WIRING AND OVERCURRENT PROTECTION

8. Show the following on plan:
- Wire type shall be 90° C wet and continuous rated
 - Overcurrent protection on inverter output circuit is sufficient

ROOF INFORMATION (ROOF TOP SYSTEM)

9. Show the following information on plan:
- Weight of the arrays (pounds per square foot including mounting hardware)
 - Describe and show the roof structural elements
 - Identify roof type
 - Provide detail of photovoltaic panel mounting hardware attachment to the roof framing members
 - Provide mounting hardware manufacturer specification
 - Where systems are 7 KW or larger, provide engineering calculations for dead load, lateral resistance, and wind uplift effects.

REQUIRED PHOTOVOLTAIC SIGNS

1. DC COMBINER/ JUNCTION BOX:

- “Warning. Electrical shock hazard. The direct current circuit conductors of this photovoltaic power system are ungrounded but may be energized with respect to ground due to leakage paths and/or ground faults.”

2. DC DISCONNECT:

- “Warning. Electrical shock hazard. The direct current circuit conductors of this photovoltaic power system are ungrounded but may be energized with respect to ground due to leakage paths and/or ground faults.”
- “PV system- DC disconnect”
- *At accessible location*

1) Operating current	3) Maximum system voltage
2) Operating voltage	4) Short-circuit current

3. INVERTER:

- “If a ground fault is indicated, the normally grounded conductors may be energized and ungrounded.”
- “Warning. Electrical shock hazard. Do not touch terminals. Terminals on both the line and load sides may be energized in the open position.”
- “The maximum AC output operating current_____”
- “The operating AC voltage_____”
- PV power source (DC)



City of Aliso Viejo
Building Division
12 Journey, Suite 100
Aliso Viejo, CA 92656
(949)425-2540 Fax (949)425-3899
www.cityofaliso Viejo.com

Residential Photovoltaic Incentives & Plan Submittal Guidelines

- 1) Operating current
- 2) Operating voltage
- 3) Maximum system voltage
- 4) Short-circuit current

4. AC DISCONNECT:

- a. "PV system- AC disconnect" PV Signage

5. METER:

- a. "The maximum AC output operating current_____"
- b. "The operating AC voltage_____"
- c. "Dual sources: Second source is Photovoltaic"

6. Permanent directory or plaque providing location of service disconnecting means and photovoltaic system disconnecting means, if not located at the same location.

INSPECTIONS:

After completing the installation, call for a final Building and Electrical inspection of the panels and related equipment. Same day combination building and electrical inspections are provided Monday-Friday when requested by 6:00am. Inspections can be made any time (24/7) by calling the inspection request line (949)425-2545. You may request a morning or afternoon inspection (AM : 8:30am to 12pm – PM: 12pm to 3pm).

SAMPLE SITE PLAN

Site plan shown is to illustrate the necessary information required for full plan review. Complete and accurate site plan is required for review and approval.

For additional information regarding this permit process, please contact the Building Department at (949)425-2540.

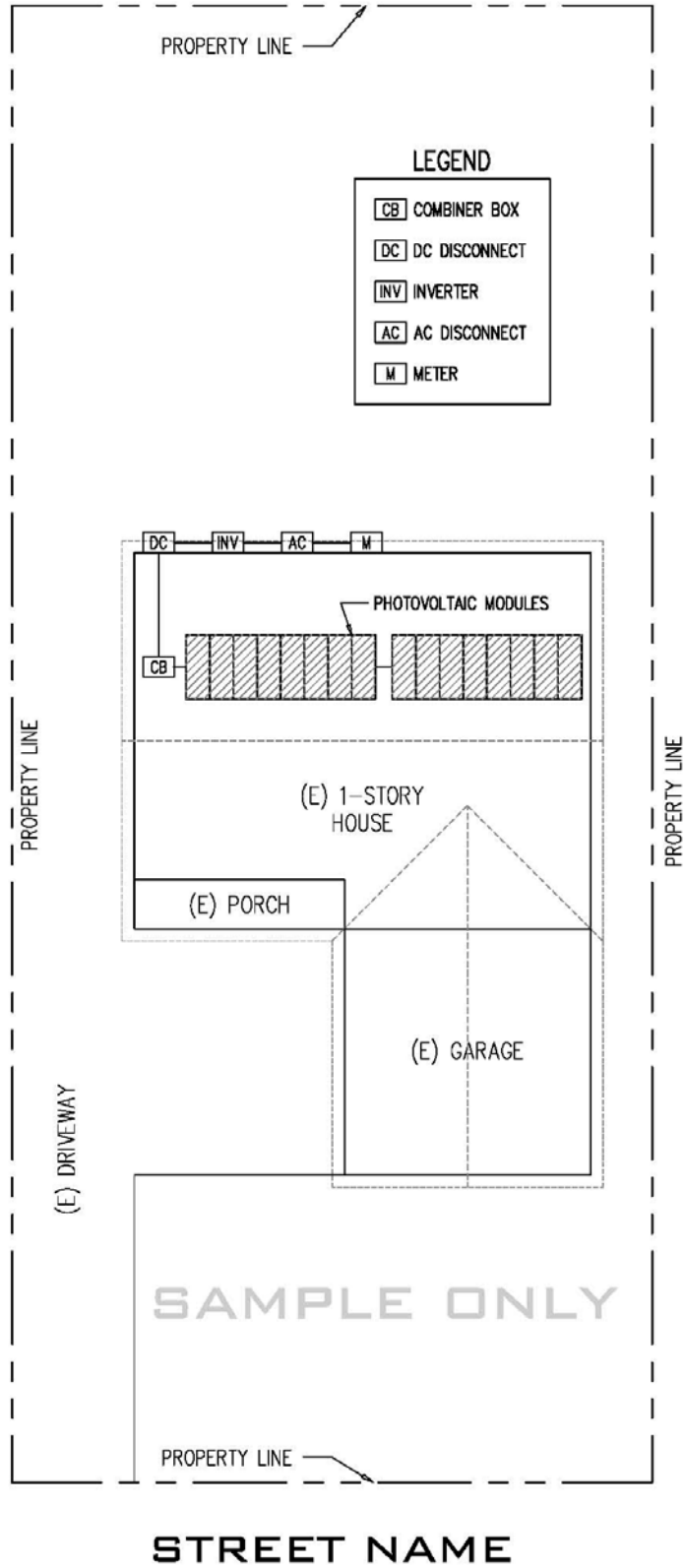

SAMPLE LINE DIAGRAM

For informational purposes only

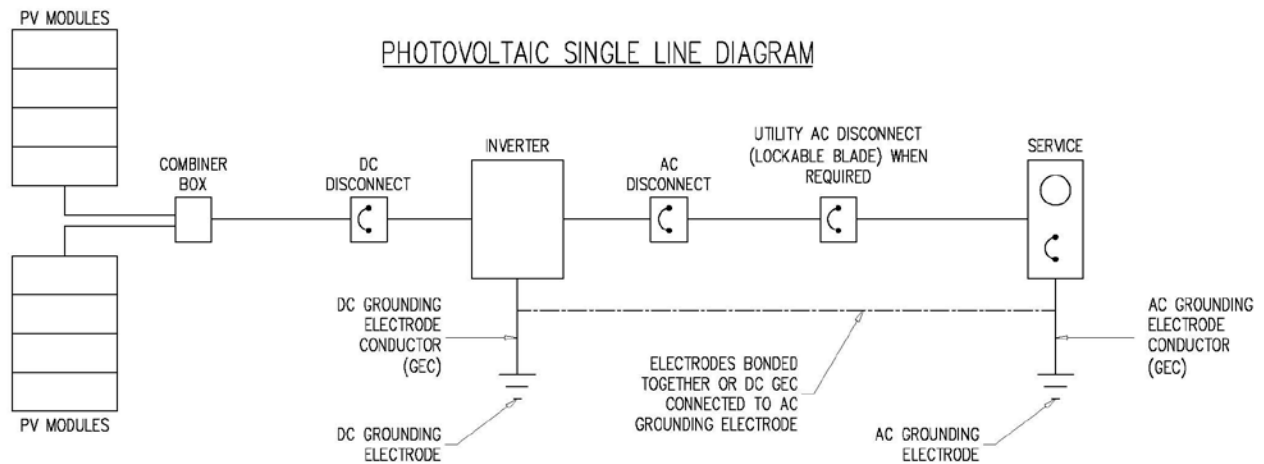

- ALL WIRING IN A SOLAR PHOTOVOLTAIC SYSTEM SHALL BE IDENTIFIED
- FOR INFORMATIONAL PURPOSES ONLY.